

Kar 45 - Kar 55

Su richiesta sono disponibili appositi supporti progettati appositamente per il sollevamento dei furgoni a passo lungo e con differenti punti di contatto

On request we have available suitable extensions designed specifically for lifting the long-wheelbase vans

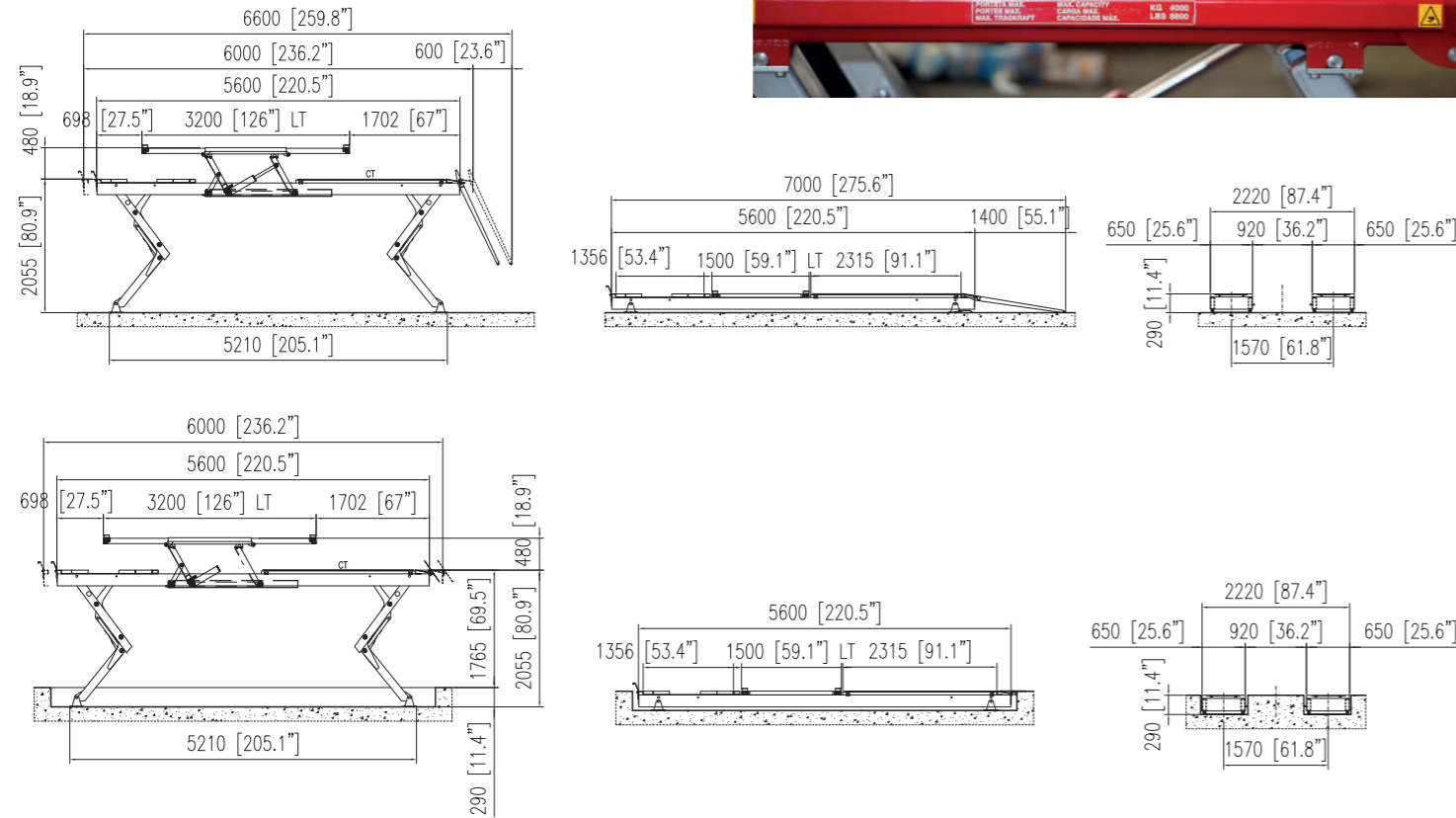
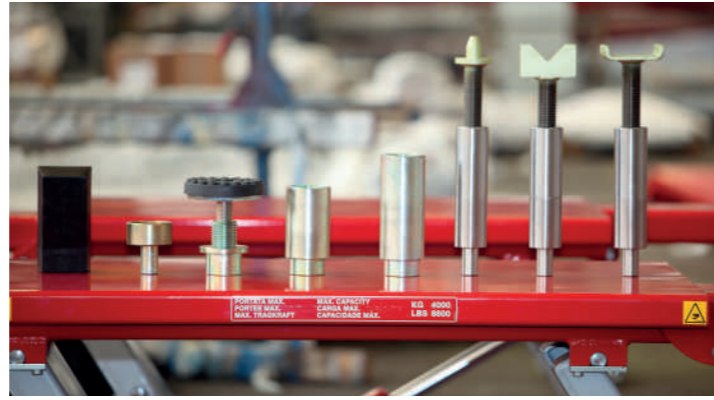

MM / KG INCH / LBS	Capacità Capacity EN1493	Portata massima Max. capacity *	Alimentazione - Feed		Pressione olio Oil pressure	Quantità olio Oil capacity	Peso Gross Weight	Tempo di salita Lifting time **
			Elettrica - Electric	Pneumatica - Air operated				
KAR 55 L= 5600	5500 kg 12.100 lbs	8000 kg 17600 lbs	230-400V/3/50 Hz 3.5 kW	8 - 10 Bar	240 Bar	30 l.	3250 kg 7150 lbs	70 s
KAR 55 L= 6000	5500 kg 12.100 lbs	8000 kg 17600 lbs	230-400V/3/50 Hz 3.5 kW	8 - 10 Bar	240 Bar	30 l.	3350 kg 7370 lbs	70 s

(*) A carico simmetrico - Whit symmetrical load



O.M.E.R. Spa Via G. Galilei, 20
30035 Mirano Venezia ITALY
Tel. ++39 041 5700303
Fax ++39 041 5700273
E-mail: info@omerlift.com
www.omerlift.com



I ponti O.M.E.R. sono modelli esclusivi omologati ed approvati dai maggiori enti di controllo internazionali. Ogni violazione dei diritti O.M.E.R. sarà perseguita a norma di legge. Ogni dato tecnico esposto nel presente catalogo è soggetto alle modifiche che la casa costruttrice si riserva di apportare in qualunque momento senza preavviso e senza alcuna responsabilità ed obbligo a carico O.M.E.R.

O.M.E.R. Lifts are exclusive models homologated and approved by the major international controlling bodies. Any violation of O.M.E.R.'s rights shall be prosecuted according to law. The manufacturer reserves the right to change the product specifications without notice and liability.

GS PRINTING GROUP - 2000 - 07/2016

SOLLEVATORI PER VEICOLI
VEHICLE LIFTS



Kar 45 - Kar 55



Kar 45 - Kar 55



Sollevatore elettroidraulico a sollevamento verticale da assetto. Sinonimo di grande prestazione e totale libertà di movimento per l'operatore. Offre massima solidità e precisione durante la convergenza dei veicoli. La particolare struttura ed il nuovo sistema brevettato ASO (Absorbing System OMER) rendono il ponte stabile ed atto ad assorbire qualsiasi tipo di stress meccanico dovuto ad irregolari distribuzioni di carico sul ponte. Realizzato nella versione da 4,5 Tons (KAR 45) e da 5,5 Tons (KAR 55), quest'ultimo è disponibile in tre diverse lunghezze 5.200 mm, 5.600 mm e 6.000 mm.

VERSIONI:

- N:** corsia non accessoriata
- CA:** versione con incavo anteriore per alloggiamento piatti rotanti e/o piatti prova giochi
- CT:** versione per convergenza totale con incavo anteriore e piatti oscillanti posteriori
- LT:** versione con sollevatore ausiliario libera ruote
- LTS:** solo per KAR 55 con lunghezza 5.600 mm e 6.000 mm

Il sollevatore è già conforme all'aggiornamento della norma europea EN 1493.



Vertical electro-hydraulic lift for alignment purposes. Synonymous of great performance and total freedom of movement for the operator. This lift offers maximum strength and precision while carrying out the wheel convergence of the vehicles. The innovative structure together with the new patented system ASO (Absorbing System OMER) makes this lift stable and apt to absorb any kind of mechanical stress due to irregular load distributions on the lift. "Kar" is realized in the version of 4,5 Tons (KAR 45) and of 5,5 Tons (KAR 55). KAR 55 is available in three different lengths 5.200 mm, 5.600 mm and 6.000 mm.

VERSIONS:

- N:** platform not equipped
- CA:** front recess for turn plates and/or playdetectors
- CT:** total convergence with front recess and rear slip plates
- LT:** auxiliary lift for wheel free working
- LTS:** only for KAR 55 with length 5.600 mm and 6.000 mm

The lift is already consistent with the updating of the european norm EN 1493.

KAR 45 L=5000 mm (LT 4.000 kg - 8.800 lbs)

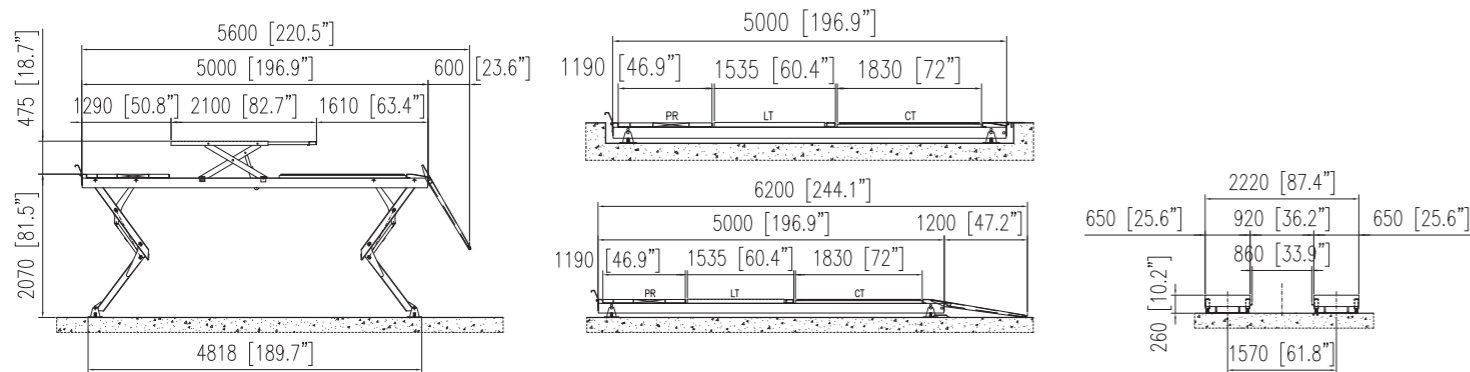

KAR 55 L=5200 mm (LT 4.000 kg - 8.800 lbs)

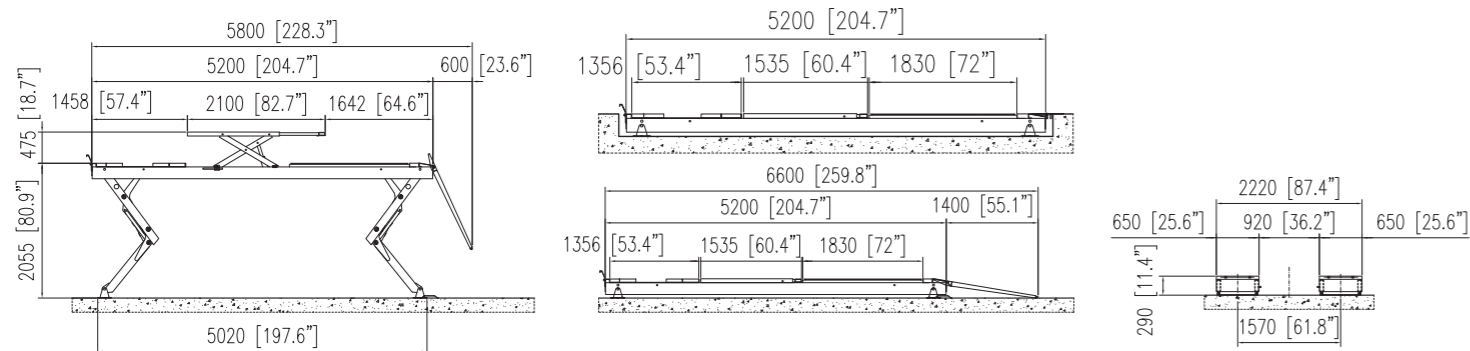

MM / KG INCH / LBS	Capacità Capacity EN1493	Portata massima Max. capacity *	Alimentazione - Feed		Pressione olio Oil pressure	Quantità olio Oil capacity	Peso Gross Weight	Tempo di salita Lifting time **
			Elettrica - Electric	Pneumatica - Air operated				
KAR 45 L= 5000	4500 kg 10.000 lbs	6000 kg 13200 lbs	230-400V/3/50 Hz 2.5 kW	8 ÷ 10 Bar	220 Bar	25 l.	2170 kg 4770 lbs	50 s
KAR 55 L= 5200	5500 kg 12.100 lbs	8000 kg 17600 lbs	230-400V/3/50 Hz 3.5 kW	8 ÷ 10 Bar	240 Bar	30 l.	2750 kg 6050 lbs	70 s
KAR 55 L= 5600	5500 kg 12.100 lbs	8000 kg 17600 lbs	230-400V/3/50 Hz 3.5 kW	8 ÷ 10 Bar	240 Bar	30 l.	2850 kg 6270 lbs	70 s

(*) A carico simmetrico - Whit symmetrical load
(**) Con portata nominale - Whit nominal capacity

Kar 45 - Kar 55

KAR 55 L=5600 mm - L=6000 mm LTS (Lift Table Super with capacity 4.000 kg - 8.800 lbs)



Per le corsie del kar 55 con lunghezze di 5600 mm e 6000 mm abbiamo realizzato un libera ruota maggiorato (LTS), particolarmente adatto al sollevamento dei veicoli commerciali a passo lungo.

E' dotato di:

- Doppia estensione , fino ad una lunghezza di 3,2 m, con portata rivista
- Doppia prolunga trasversale per presa sottoscocca
- Struttura solida ed affidabile
- Capacità 4 Ton



For the platforms of the KAR 55 with length of 5600 mm and 6000 mm we have developed the new free oversized lift table (LTS) which is particularly suitable for the lifting of commercial vehicles with long wheelbase .

It's equipped with :

- Double extension , up to a length of 3.2 m, with revised capacity
- Double traversal extension for chassis contact points
- Sturdy and reliable structure
- Capacity 4 Tons

